



**BERETTA® T47 geo**

Perforatrice Idraulica • Hydraulic Drilling



Caratteristiche tecniche	Technical data	
<b>MOTORE DIESEL SILENZIATO</b> tipo potenza rumorosità motore capacità serbatoio gasolio	<b>DIESEL ENGINE</b> type power noise engine fuel tank capacity	<b>PERKINS 1104D.44TA</b> <b>107 KW</b> <b>71 dBA</b> <b>140 l</b>
<b>CARRO CINGOLATO</b> velocità pendenza massima superabile pressione specifica al suolo larghezza pattini in acciaio larghezza carro cingolato	<b>CRAWLERS width</b> speed max gradeability ground bearing pressure steel shoe width crawlers width	<b>0 - 3 km/h</b> <b>55%</b> <b>5,70 N/cm2</b> <b>300 mm</b> <b>1600 mm</b>
<b>SLITTA S5</b> corsa carrello testa rotazione tiro-spinta massimo motoriduttore velocità salita-discesa rapida	<b>MAST S5</b> stroke of rotary head ratiomotor pull-push rapid up-down speed	<b>4300 mm</b> <b>90 kN</b> <b>30 m/min</b>
<b>TESTA ROTAZIONE 56-4V-85S CON MARTELLO-OPTIONAL</b> numero marce 1° marcia: coppia / giri 2° marcia: coppia / giri 3° marcia: coppia / giri 4° marcia: coppia / giri corsa spostamento laterale	<b>56-4V-85S ROTARY HEAD WITH HAMMER-OPTIONAL</b> speed number 1st speed: torque rpm 2st speed: torque rpm 3st speed: torque rpm 4st speed: torque rpm sideways travel stroke	<b>4</b> <b>1200 daNm/43 rpm</b> <b>600 daNm/86 rpm</b> <b>304 daNm/170 rpm</b> <b>152 daNm/340 rpm</b> <b>470 mm</b>
<b>MORSA STANDARD</b> diametri bloccaggio forza di chiusura coppia svitamento	<b>STANDARD CLAMP</b> blocking diameter clamping force break-out torque	<b>50 - 324 mm</b> <b>140 KN</b> <b>52 KNm</b>
<b>ARGANO WIRELINE - OPTIONAL</b> diametro fune capacità fune tiro massimo velocità massima	<b>WIRELINE WINCH-OPTIONAL</b> rope diameter rope capacity max line pull max speed	<b>6 mm</b> <b>297 m - nr. 8 strati</b> <b>900 kg</b> <b>100 m/min</b>
<b>IMPIANTO IDRAULICO</b> nr. 6 pompe a ingranaggi portata pompa nr. 1 portata pompa nr. 2 portata pompa nr. 3 portata pompa nr. 4 portata pompa nr. 5 portata pompa nr. 6 pressione massima capacità serbatoio idraulico	<b>HYDRAULIC SYSTEM</b> no. 6 gears pumps oil flow pump no. 1 oil flow pump no. 2 oil flow pump no. 3 oil flow pump no. 4 oil flow pump no. 5 oil flow pump no. 6 max pressure oil sump capacity	<b>75 l/min</b> <b>60 l/min</b> <b>35 l/min</b> <b>75 l/min</b> <b>75 l/min</b> <b>35 l/min</b> <b>260 Bar</b> <b>350 l</b>
<b>PESO TOTALE MACCHINA</b>	<b>WEIGHT TOTAL MACHINE</b>	<b>8,0 ton</b>

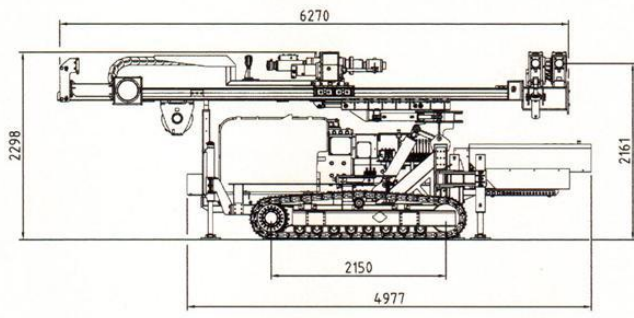
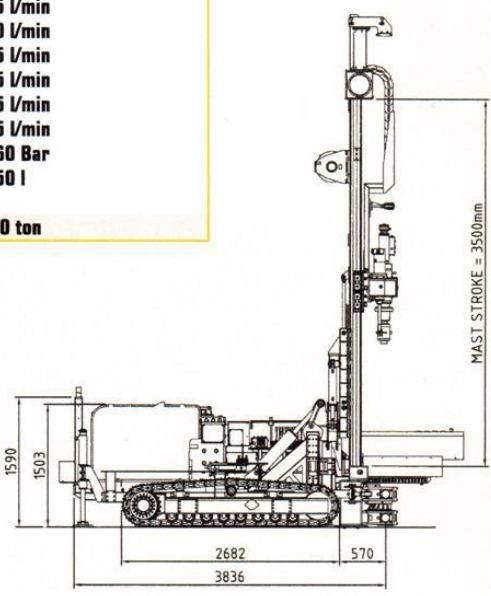
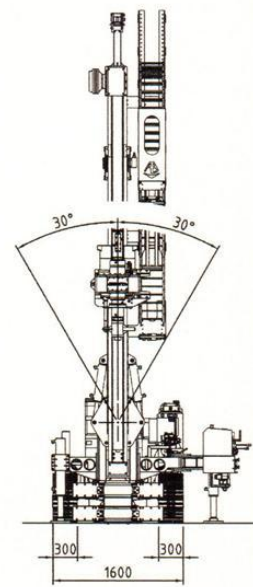

## Beretta Alfredo s.r.l.

20842 BESANA IN BRIANZA (MB) - ITALIA - Via Vignareto, 10  
 Tel. +39 (0)362 99.53.80 r.a. - Fax +39 (0)362 99.57.08  
 www.berettaalfredo.it - e.mail: info@berettaalfredo.it

